

Overview

Mellanox SH2200 TAA Switch Module for HPE Synergy

Mellanox SH2200 TAA Switch Module for HPE Synergy delivers high-performance, high-speed 25Gb and 50Gb Ethernet connectivity to the Synergy compute modules, and 40/100Gb Ethernet to the upstream network switches. Designed for hybrid IT data centers requiring advanced feature sets such as deterministic low latency network fabric, hardware-based virtualization support, or storage offloading. Based on the Mellanox Spectrum™ ASIC, the module delivers up to 2.8 Tbps switching capacity, 8.4 BPPS throughput and ultra low latency for the most demanding data center workloads such as Network Function Virtualization, financial services, high frequency trading, or virtualized enterprise data centers.

HPE Synergy is a single infrastructure of physical and virtual pools of compute, storage, and fabric resources, and a management interface that allows configuration of server resources in any configuration. The Mellanox SH2200 Switch Module is managed by industry standard management resources that allows network functions to be managed by network administrators. As the foundation for the New Style of Business infrastructure, HPE Synergy eliminates hardware and operational complexity so IT organizations can precisely deliver infrastructure resources to applications faster and with greater flexibility.

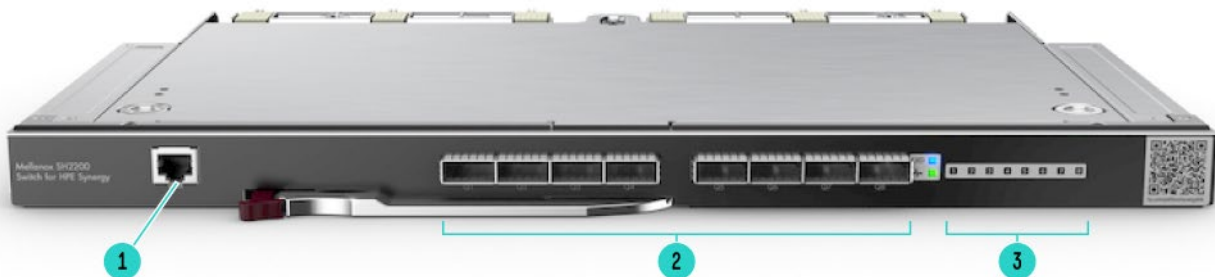

Figure 1 Mellanox SH2200 Switch Module for HPE Synergy Bezel

1. Console port
2. 40/100Gb QSFP28 Ethernet uplink ports
3. Status LEDs

Overview

Platform Information

Models

Mellanox SH2200 TAA-compliant Switch Module for HPE Synergy

866573-B21

Notes: HPE offers multiple Trade Agreement Act (TAA) compliant configurations to meet the needs of US Federal Government customers. This product is either manufactured or substantially transformed in a designated country.

Compatibility

Mellanox SH2200 TAA Switch Module for HPE Synergy supports the following hardware.

Obsolete Products*

Notes: *No longer available for purchase, informational only

- HPE Synergy 480 Gen9 Configure-to-order Compute Module
 - HPE Synergy 480 Gen9 Configure-to-order without Drive Bays Compute Module
 - HPE Synergy 480 Gen9 Configure-to-order Premium Compute Module
 - HPE Synergy 620 Gen9 2S-EX Configure-to-order Compute Module
 - HPE Synergy 620 Gen9 2S Base Build-to-order Compute Module
 - HPE Synergy 620 Gen9 2S-EX Performance Build-to-order Compute Module
 - HPE Synergy 660 Gen9 E5-4610v4 2P Compute Module Entry BTO
 - HPE Synergy 660 Gen9 E5-4650v4 4P Compute Module Performance BTO
 - HPE Synergy 660 Gen9 Configure-to-Order SAS Compute Module
 - HPE Synergy 660 Gen9 Configure-to-Order SATA Compute Module
 - HPE Synergy 660 Gen9 Configure-to-Order Expanded Storage Compute Module
 - HPE Synergy 680 Gen9 4S-EX Configure-to-Order Compute Module
 - HPE Synergy 680 Gen9 4S-EX Build-to-order Base Compute Module
 - HPE Synergy 680 Gen9 4S-EX Build-to-order Performance Compute Module
-



Overview

Supported Configurations



HPE Synergy 12000 Frame - Rear View

Mezzanines to Interconnect Port Mapping

The first interconnect in an ICM bay set is connected to Port 1 of the mezzanine card and the second interconnect in an ICM bay set is connected to Port 2 of that mezzanine card. If the two interconnects in an ICM bay set are of the same type, they provide redundant connectivity to the two mezzanine ports.

Notes: Dotted lines in the figure below indicate paired Interconnect Bay

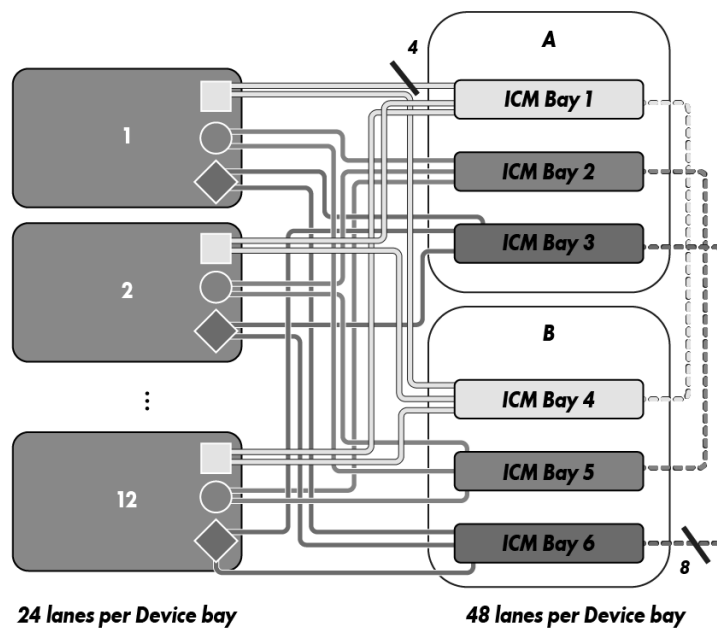

Standard Features

Product Features

Performance

- 12 x 25/50Gb Ethernet downlinks to compute module Ethernet Adapters
- Each 25/50Gb downlink supports one Ethernet connectivity to the adapter
- 8 x QSFP28 external uplink ports configurable as 1x100Gb, 1x40Gb, 4x25Gb or 4x10Gb Ethernet ports connected to external LAN switches
- Extended list of direct attach copper and active optical cable connections supported
- Ultra low latency (<300 ns Ethernet ports)
- Line-rate, full-duplex 2.8 Tbps switching capacity with 8.4 BPPS throughput
- Hardware-based VXLAN VTEP support

Management

- Monitored by HPE OneView
- CLI support, SSH and Console, IPv4 and IPv6, for configuration and troubleshooting, integrated with security architecture and multi-level user administration
- Web UI
- RMON2
- Status and statistics reporting, system health, port status, through CLI and SNMP
- 802.1AB Link Layer Discovery Protocol (LLDP) v1, v2
- Dual flash images
- Multiple configuration files
- Telnet
- SSHv2
- SNMP v1, v2, v3
- Syslog client, both IPv4 and IPv6
- Network Time Protocol (NTP)
- Secure Copy (SCP), FTP & TFTP
- STP Root Guard
- DHCP protection from unauthorized DHCP servers
- RADIUS
- TACACS+
- sFLOW
- Port mirroring
- Port counters
- Event notification
- JSON
- Puppet Agent
- Mellanox NEO™
- OpenFlow 1.4
- Notification by E-Mail
- Predefined Scheduled Scripts
- System Health Monitoring
- Enhanced Telemetry



Standard Features

Layer 2 Switching

- 88K L2 forwarding entries
- 802.1Q VLAN support (4094 VLAN)
- Jumbo Frame (9216 bytes)
- Q-in-Q
- 802.3ad Link Aggregation/LACP
 - 32 ports/channel
 - 64 groups per system
- Multi-module Chassis Link Aggregation Group (MLAG)
- 802.3X Flow Control
- 802.1Qbb Priority-based Flow Control (PFC)
- 802.1Qaz Enhanced Transmission Selection (ETS)
- 802.1Qau Congestion Notification
- Data Center Bridging Capabilities Exchange Protocol (DCBX)
- RFC3168 Explicit Congestion Notification (ECN)
- ICMP – IPv4 and IPv6
- IGMPv1, v2, v3 snooping, Querier
- 802.1W Rapid Spanning Tree Protocol (RSTP)
 - BPDU filter
 - Root guard
 - Loop guard
 - BPDU guard
- 802.1Q Multiple Spanning Tree Protocol (MSTP)
- Per-VLAN Rapid Spanning Tree+ (PVRST+)
- Access control lists (ACL) – (L2 – L4)
- 802.1X Port-based Network Access Control
- QoS – qualification, rewrite, policers

Layer 3 Switching

- Static Routing
- IPv4
- IPv6
- OSPFv2
- BGPv4
- 64-way ECMP
- Virtual Router Redundancy Protocol (VRRPv2)
- PIM Bi-Dir
- DHCP Relay
- Remote Direct Memory Access (RDMA) over Converged Ethernet (RoCEv2)
- VXLAN Tunnel End Point (VTEP)
- Open vSwitch Database (OVSDDB)



Standard Features

SNMP MIBs

- RFC 4293 IP-MIB
- RFC 2572 SNMP-MPD-MIB
- RFC 4268 ENTITY-STATE-MIB
- RFC 3433 ENTITY-SENSOR-MIB
- RFC 4133 ENTITY-MIB
- RFC 4188 BRIDGE-MIB
- RFC 4363 Q-BRIDGE-MIB
- 802.1AB-2005 LLDP-MIB
- RFC 4318 RSTP-MIB
- RFC 2863 IF-MIB
- LANAifType-MIB
- RFC 4001 INET-ADDRESS-MIB
- RFC 4022 TCP-MIB
- RFC 4113 UDP-MIB
- RFC 4292 IP-FORWARD-MIB
- RFC 2790 HOST-RESOURCES-MIB
- RFC 1213
- SNMPV2-CONF
- RFC 2579 SNMPV2-TC MIB
- RFC 3417 SNMPV2-TM MIB
- RFC 3826 SNMP-USM-AES-MIB
- Mellanox SMI MIB
- Mellanox IF-VPI-MIB
- Mellanox enhanced ENTITY-MIB
- Mellanox Power-Cycle-MIB
- Mellanox SW-Update-MIB
- Mellanox Config-MIB

Options

- Optional HPE 100Gb QSFP28 SR4 modules
- Optional HPE 40Gb QSFP+ SR, SR 300M and LR modules, 40Gb QSFP+ DAC and AOC cables

Supports Ethernet adapters for HPE Synergy Compute Nodes (Supported functionality defined by each adapter)



Service and Support

HPE Services

No matter where you are in your digital transformation journey, you can count on HPE Services to deliver the expertise you need when, where and how you need it. From planning to deployment, ongoing operations and beyond, our experts can help you realize your digital ambitions.

<https://www.hpe.com/services>

Consulting Services

No matter where you are in your journey to hybrid cloud, experts can help you map out your next steps. From determining what workloads should live where, to handling governance and compliance, to managing costs, our experts can help you optimize your operations.

<https://www.hpe.com/services/consulting>

HPE Managed Services

HPE runs your IT operations, providing services that monitor, operate, and optimize your infrastructure and applications, delivered consistently and globally to give you unified control and let you focus on innovation.

[HPE Managed Services | HPE](#)

Operational services

Optimize your entire IT environment and drive innovation. Manage day-to-day IT operational tasks while freeing up valuable time and resources. Meet service-level targets and business objectives with features designed to drive better business outcomes.

<https://www.hpe.com/services/operational>

HPE Complete Care Service

HPE Complete Care Service is a modular, edge-to-cloud IT environment service designed to help optimize your entire IT environment and achieve agreed upon IT outcomes and business goals through a personalized experience. All delivered by an assigned team of HPE Services experts. HPE Complete Care Service provides:

- A complete coverage approach -- edge to cloud
- An assigned HPE team
- Modular and fully personalized engagement
- Enhanced Incident Management experience with priority access
- Digitally enabled and AI driven customer experience

<https://www.hpe.com/services/complecare>

HPE Tech Care Service

HPE Tech Care Service is the operational support service experience for HPE products. The service goes beyond traditional support by providing access to product specific experts, an AI driven digital experience, and general technical guidance to not only reduce risk but constantly search for ways to do things better. HPE Tech Care Service delivers a customer-centric, AI driven, and digitally enabled customer experience to move your business forward. HPE Tech Care Service is available in three response levels. Basic, which provides 9x5 business hour availability and a 2-hour response time. Essential which provides a 15-minute response time 24x7 for most enterprise level customers, and Critical which includes a 6-hour repair commitment where available and outage management response for severity 1 incidents.

<https://www.hpe.com/services/techcare>



Service and Support

HPE Lifecycle Services

HPE Lifecycle Services provide a variety of options to help maintain your HPE systems and solutions at all stages of the product lifecycle. A few popular examples include:

- Lifecycle Install and Startup Services: Various levels for physical installation and power on, remote access setup, installation and startup, and enhanced installation services with the operating system.
- HPE Firmware Update Analysis Service: Recommendations for firmware revision levels for selected HPE products, taking into account the relevant revision dependencies within your IT environment.
- HPE Firmware Update Implementation Service: Implementation of firmware updates for selected HPE server, storage, and solution products, taking into account the relevant revision dependencies within your IT environment.
- Implementation assistance services: Highly trained technical service specialists to assist you with a variety of activities, ranging from design, implementation, and platform deployment to consolidation, migration, project management, and onsite technical forums.
- HPE Service Credits: Access to prepaid services for flexibility to choose from a variety of specialized service activities, including assessments, performance maintenance reviews, firmware management, professional services, and operational best practices.

Notes: To review the list of Lifecycle Services available for your product go to:

<https://www.hpe.com/services/lifecycle>

For a list of the most frequently purchased services using service credits, see the [HPE Service Credits Menu](#)

Other Related Services from HPE Services:

HPE Education Services

Training and certification designed for IT and business professionals across all industries. Broad catalogue of course offerings to expand skills and proficiencies in topics ranging from cloud and cybersecurity to AI and DevOps. Create learning paths to expand proficiency in a specific subject. Schedule training in a way that works best for your business with flexible continuous learning options.

<https://www.hpe.com/services/training>

Defective Media Retention

An option available with HPE Complete Care Service and HPE Tech Care Service and applies only to Disk or eligible SSD/Flash Drives replaced by HPE due to malfunction.

Consult your HPE Sales Representative or Authorized Channel Partner of choice for any additional questions and services options.

Parts and Materials

HPE will provide HPE-supported replacement parts and materials necessary to maintain the covered hardware product in operating condition, including parts and materials for available and recommended engineering improvements.

Parts and components that have reached their maximum supported lifetime and/or the maximum usage limitations as set forth in the manufacturer's operating manual, product quick-specs, or the technical product data sheet will not be provided, repaired, or replaced as part of these services.

How to Purchase Services

Services are sold by Hewlett Packard Enterprise and Hewlett Packard Enterprise Authorized Service Partners:

- Services for customers purchasing from HPE or an enterprise reseller are quoted using HPE order configuration tools.
- Customers purchasing from a commercial reseller can find services at <https://ssc.hpe.com/portal/site/ssc/>



Service and Support

AI Powered and Digitally Enabled Support Experience

Achieve faster time to resolution with access to product-specific resources and expertise through a digital and data driven customer experience

Sign into the HPE Support Center experience, featuring streamlined self-serve case creation and management capabilities with inline knowledge recommendations. You will also find personalized task alerts and powerful troubleshooting support through an intelligent virtual agent with seamless transition when needed to a live support agent.

<https://support.hpe.com/hpesc/public/home/signin>

Consume IT On Your Terms

HPE GreenLake edge-to-cloud platform brings the cloud experience directly to your apps and data wherever they are—the edge, colocations, or your data center. It delivers cloud services for on-premises IT infrastructure specifically tailored to your most demanding workloads. With a pay-per-use, scalable, point-and-click self-service experience that is managed for you, HPE GreenLake edge-to-cloud platform accelerates digital transformation in a distributed, edge-to-cloud world.

- Get faster time to market
- Save on TCO, align costs to business
- Scale quickly, meet unpredictable demand
- Simplify IT operations across your data centers and clouds

To learn more about HPE Services, please contact your Hewlett Packard Enterprise sales representative or Hewlett Packard Enterprise Authorized Channel Partner. Contact information for a representative in your area can be found at "Contact HPE"

<https://www.hpe.com/us/en/contact-hpe.html>

For more information

<http://www.hpe.com/services>



Related Options

QSFP28 uplink ports options

HPE 100Gb QSFP28 MPO SR4 100m Transceiver	845966-B21
HPE 100Gb QSFP28 Bidirectional Transceiver	845972-B21
HPE 100Gb QSFP28 to QSFP28 3m Direct Attach Copper Cable	845406-B21
HPE 100Gb QSFP28 to QSFP28 5m Direct Attach Copper Cable	845408-B21
HPE QSFP28 to SFP28 Adapter	845970-B21

Notes: HPE QSA28 (QSFP28 to SFP28) adapter (845970-B21) is required to convert a QSFP+/QSFP28 slot to a single SFP+/SFP28 slot for 25G or 10G operation with this switch model.

QSFP+ uplink ports options

HPE BladeSystem c-Class 40Gb QSFP+ MPO SR4 100m Transceiver	720187-B21
HPE 40Gb QSFP+ Bidirectional Transceiver	841716-B21
HPE BladeSystem c-Class 40G QSFP+ to QSFP+ 15m Active Optical Cable	720211-B21
HPE BladeSystem c-Class QSFP+ to 4x10G SFP+ 15m Active Optical Cable	721076-B21

SFP+ uplink ports options

HPE 10GBASE-T SFP+ RJ45 30m 1-pack Transceiver	R0R41B
HPE BladeSystem c-Class 10Gb SFP+ SR Transceiver	455883-B21
HPE Networking X240 10G SFP+ SFP+ 0.65m DAC Cable	JD095C

HPE Synergy Services

Notes: See [HPE Support Services Central](#) for additional services at [HPE Global IT Services-Infrastructure and Business Technology Services | HPE](#)

Deployment/Installation & Start-up Services

HPE Factory Express Synergy Initial Frame Package 4 Service	HA454A1-300
HPE Factory Express Synergy Add-on Frame Package 4 Service	HA454A1-301
HPE Synergy First Frame Startup Service	U8JM3E
HPE Synergy Additional Frame Startup Service	U8JM4E



Technical Specifications

Shipping Dimensions	Length	19.53 in (496 mm)		
	Width	15.59 in (396 mm)		
	Height	5.87 in (149 mm)		
Shipping Weight	Weight	Approximately 5.3Kg (11.7 Lbs)		
Product Specifications Hardware	Performance	Line-rate, full-duplex 2.8 Tbps Ethernet fabric		
		Non-blocking architecture		
		Maximum transmission unit (MTU) of up to 12000 bytes (super jumbo frames)		
	Connectors and Cabling	12 x 25/50Gb downlinks through the midplane 8 x 40/100Gb QSFP28 uplink ports Console port		
	Indicators	QSFP28 port LED Health LED UID LED		
	Weight	4.00Kg (8.8 Lbs)		
	Latency	<300 ns		
	Environmental Ranges	Temperature Range		
		Specification	10°C to 40°C (50°F to 104°F)*	
		Temperature Range		
Operating		10°C to 40°C (50°F to 104°F)		
Shipping		Shipping -40°C to 70°C (-40°F to 158°F)		
Storage		-30°C to 60°C (-22°F to 140°F)		
Maximum wet bulb temperature		38.7°C (101.66°F)		
Relative Humidity (noncondensing)				
Operating	5% to 95%			
Shipping	5% to 95%			
Notes:				
<ul style="list-style-type: none"> – All temperature ratings shown are for sea level. An altitude derating of 1°C per 304.8 m (1.8°F per 1,000 ft) to 3048 m (10,000 ft) is applicable. No direct sunlight allowed. Upper operating limit is 3,048m (10,000 ft) or 70 Kpa/10.1 psia. Upper non-operating limit is 9,144 m (30,000 ft) or 30.3 KPa/4.4 psia. – Storage maximum humidity of 95% is based on a maximum temperature of 45°C (113°F). Altitude maximum for storage corresponds to a pressure minimum of 70 KPa. 				
	Power Specification	12V @ 17A (200 W max)		

Safety and Compliance

To view the regulatory information for your product, view the Safety and Compliance Information for Server, Storage, Power, Networking, and Rack Products, available at the Hewlett Packard Enterprise Support Center: [Document - Safety and Compliance Information for Server, Storage, Power, Networking, and Rack Products | HPE Support](#)

Environment-friendly Products and Approach

End-of-life Management and Recycling

Hewlett Packard Enterprise Enterprise offers end-of-life Hewlett Packard Enterprise product return, trade-in, and recycling programs in many geographic areas. For trade-in information, please go to: <http://www.hpe.com/info/recycle>. To recycle your product, please go to: <http://www.hpe.com/info/recycle> or contact your nearest Hewlett Packard Enterprise sales office. Products returned to Hewlett Packard Enterprise will be recycled, recovered or disposed of in a responsible manner.

The EU WEEE directive (2002/95/EC) requires manufacturers to provide treatment information for each product type for use by treatment facilities. This information (product disassembly instructions) is posted on the Hewlett Packard Enterprise web site at: <http://www.hpe.com/info/recycle>. These instructions may be used by recyclers and other WEEE treatment facilities as well as Hewlett Packard Enterprise OEM customers who integrate and re-sell Hewlett Packard Enterprise equipment.

Summary of Changes

Date	Version History	Action	Description of Change
19-Feb-2024	Version 8	Changed	Networking product names were updated.
04-Dec-2023	Version 7	Changed	Service and Support section was updated
01-May-2023	Version 6	Changed	Service and Support section was updated Updated Gen10Plus compatibility
15-Nov-2021	Version 5	Changed	Service and Support Pointnext Tech Care and Complete Care information updated
02-Aug-2021	Version 4	Changed	Added more network adapters and transceivers to the document Overview and Related Options sections were updated Service and Support Pointnext information added Obsolete SKUs were removed
05-Nov-2018	Version 3	Changed	Platform Information section was updated. Obsolete SKUs were deleted: 720190-B21, 720208-B21, 721073-B21.
23-Oct-2017	Version 2	Changed	Platform Information, Service and Support and Technical Specifications sections were updated. SKUs added in Related Options section: 845404-B21, 845406-B21, 845408-B21.
11-Jul-2017	Version 1	Created	New QuickSpecs



Copyright

**Make the right purchase decision.
Contact our presales specialists.**

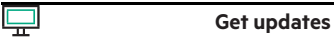
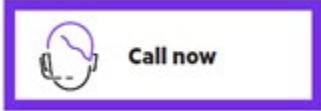
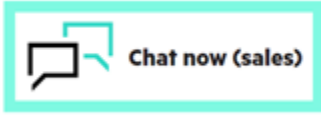

© Copyright 2024 Hewlett Packard Enterprise Development LP. The information contained herein is subject to change without notice. The only warranties for Hewlett Packard Enterprise products and services are set forth in the express warranty statements accompanying such products and services. Nothing herein should be construed as constituting an additional warranty. Hewlett Packard Enterprise shall not be liable for technical or editorial errors or omissions contained herein.

a00008519enw - 15940 - Worldwide - V8 - 19-February-2024